

High Temperature and acid alkali resistant tag



High Temperature Resistant

Withstand high temperature up to 280°C, withstand 230°C for long time.

Acid Alkali resistant

Anti acid and alkali, can be used in harsh environment, strong acid and alkali.

Applied on metal surface

The read range on metal can be up to 1.5m.

Devil-3000

Product Datasheet



Functional Specifications:

RFID Protocol:	EPC Class1 Gen2, ISO18000-6C
Frequency:	US(902-928MHZ), EU(865-868MHZ)
IC type:	Alien Higgs-3
Memory:	EPC 96bits (Up to 480bits) , USER 512bits, TID64bits
Write Cycles:	100,000 times
Functionality:	Read/write
Data Retention:	50 Years
Applicable Surface:	Metal Surfaces
Read Range : (Fix Reader)	1.5m , US (902-928MHZ) 1.5m , EU (865-868MHZ)
Read Range : (Handheld Reader)	1.0m , US (902-928MHZ) 0.8m , EU (865-868MHZ)
Warranty:	1 Year

Physical Specification:

Size:	35x27mm, Hole: D2.5mmx4
Thickness:	10mm
Material:	PEEK
Colour:	Black
Mounting Methods:	Screw - Socket head cap screw(M2)
Weight:	11g

Dimensions:

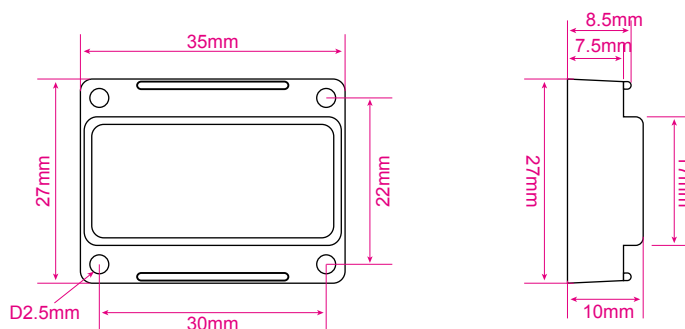

Environmental Specification:

IP Rating:	IP68, IP69K
Withstand PH:	PH0 to PH14, and all other liquid that PEEK can handle with.
Storage Temperature:	-60°C to +230°C; +260°C 1500 hours.
Operation Temperature:	-40°C to +150°C
Reliability testing terms and results:	<ul style="list-style-type: none">a. Withstand 280°C for 1000 hours continuously without damage.b. Withstand 260°C for 1500 hours continuously without damage.c. Withstand -20°C for 8 hours then 260°C for 16 hours per day, 60 days continuously without damage.d. Withstand from 150°C to -40°C, 7.5 cycles per day, 80 days continuously with total 600 cycles without damage.e. Withstand 260°C for 100 hours continuously then soaking in 2m depth water for 48 hours, without seepage or damage.
compression strength:	150Mpa
Certifications:	Reach Approved, RoHS Approved, CE Approved, ATEX Approved.